

# Silver coating on carbon and SiC fibres

S. G. WARRIER, R. Y. LIN

*Department of Materials Science and Engineering, University of Cincinnati, M. L. 12, Cincinnati, OH 45221, USA*

Electroless silver coating on carbon fibres using silver nitrate solutions has been studied. It was observed that the rate of silver coating depends on the degree of graphitization of carbon fibres. Fibres with a higher degree of graphitization were coated faster than those with a lower degree of graphitization. A physical model considering the number of nucleation sites on the carbon fibre surface as a function of the degree of graphitization is proposed for the silver coating process. The strength and modulus of coated and uncoated fibres have been determined using a high-sensitivity load cell with an Instron tensile testing machine. It was observed that silver coating did not alter the strength or modulus of the fibre. Aluminium matrix composites have been successfully fabricated with these fibres. The same coating technique was also used to coat silicon carbide fibres. Improvement in the infiltration during composite fabrication was observed when the fibres were silver-coated.

## 1. Introduction

Carbon and graphite fibre-reinforced aluminium matrix composites are considered favourable for application in the aerospace and electrical industries primarily due to their high specific strength and good electrical and thermal conductivities. However, the preparation of this type of composite has many difficulties. This is because aluminium wets carbon only at temperatures around 1000 °C [1] and also because above 550 °C, aluminium reacts with carbon rapidly to form aluminium carbide and results in fibre degradation and reduction in strength of the composite [2–4].

In order to promote wetting between carbon fibres and molten aluminium during infiltration, thin layers of various metals like copper [5], silver [5, 6], nickel [7, 8], tantalum [9], cobalt [10] and bimetals like copper–cobalt [10] and copper–nickel [10] have been deposited on the fibre surface. Such coatings may serve multiple purposes during the fabrication of the composite. Firstly, the coating layer may form a low melting point eutectic at the interface, and thus improve the wettability of the matrix on the fibre or reduce the viscosity of molten aluminium and promote infiltration. Secondly, the coating may protect the fibres from being damaged or contaminated during processing. Silver coating on carbon fibres can facilitate infiltration of aluminium by forming a eutectic at the interface and by preventing contamination of the fibre surface during processing [2]. Silver coating on graphite fibres has been done by Sara [5] using an electroplating process. The coating evenness with such a process is a major concern since plating on one side is often significantly less than that on the other side of the fibre. Lately Cheng *et al.* [6] coated carbon fibres with silver using an electroless deposition technique. They first deposited copper and then

silver on the fibres. They observed that depositing copper first helped form a uniform silver layer on the fibres. However, the effect of various types of carbon fibres on the coating was not addressed.

This paper presents the results of fibre surface coating using electroless silver plating on carbon and graphite fibres, in an attempt to promote wetting between carbon fibres and aluminium-matrix composites fabricated by a pressureless infiltration process developed in this laboratory. Emphasis has been laid on the effects of the type of carbon fibre on the rate and characteristics of the coating. This technique has also been extended to coat silicon carbide (SiC) Nicalon fibres in order to promote wettability and facilitate the fabrication of aluminium matrix composites. Tensile strength of fibres before and after the treatment will also be reported.

## 2. Experimental procedure

### 2.1. Coating of fibres

Polyacrylonitrile (PAN) base carbon fibres (Maganamile AS from Hercules), pitch base graphite fibres (P-55 from Union Carbide), chemical vapour deposition (CVD) fibres from Applied Sciences Inc., having an average diameter of 8–10 µm and Nicalon silicon carbide (SiC) fibres from Dow Corning having an average diameter of about 20 µm were employed in this study. The coating process consisted of:

- (i) Soaking fibres in acetone for 15 min to remove the epoxy sizing (except CVD fibres).
- (ii) Immersion in 68% HNO<sub>3</sub> for 15 min to etch the fibre surface and hence increase the surface area of the fibre.
- (iii) Sensitization in an aqueous solution of 10 kg m<sup>-3</sup> of SnCl<sub>2</sub> and 4 × 10<sup>-2</sup> m<sup>3</sup> m<sup>-3</sup> of 38% HCl for 20 min.

(iv) Catalysis treatment in an aqueous solution of  $0.25 \text{ kg m}^{-3}$  of  $\text{PdCl}_2$  and  $2.5 \times 10^{-3} \text{ m}^3 \text{ m}^{-3}$  of 38% HCl for 5 min.

(v) Deposition of copper for 10 min in a solution consisting of  $10 \text{ kg m}^{-3}$   $\text{CuSO}_4$ ,  $25 \text{ kg m}^{-3}$   $\text{KNaC}_4\text{H}_4\text{O}_6 \cdot 4\text{H}_2\text{O}$  (sodium potassium tartarate),  $15 \text{ kg m}^{-3}$  NaOH and  $5 \times 10^{-3} \text{ m}^3 \text{ m}^{-3}$  of HCHO (formaldehyde).

(vi) Deposition of silver for 15 min from an aqueous solution containing

(a)  $57.69 \text{ kg m}^{-3}$   $\text{AgNO}_3$ ,  $38.46 \text{ kg m}^{-3}$  NaOH,  $0.833 \text{ m}^3 \text{ m}^{-3}$   $\text{NH}_4\text{OH}$ , and

(b)  $40 \text{ kg m}^{-3}$   $\text{C}_6\text{H}_{12}\text{O}_6$ ,  $4 \text{ kg m}^{-3}$   $\text{H}_2\text{C}_4\text{H}_4\text{O}_6$  (tartaric acid),  $0.1 \text{ m}^3 \text{ m}^{-3}$   $\text{C}_2\text{H}_5\text{OH}$ .

Fibres were rinsed in distilled water after each treatment. Copper and silver plating solutions were prepared just before the plating. HCHO was added to the copper plating solution just before the fibres were to be introduced.  $\text{AgNO}_3$  and NaOH were dissolved thoroughly in water before the addition of  $\text{NH}_4\text{OH}$ . The reducing solution (b), which was made separately, was then mixed with the silver solution (a). Silver plating was not done directly on carbon fibres because it was observed that direct silver deposition caused a non-uniform coating. A similar observation was also made by Cheng *et al.* [6].

## 2.2. Specimen characterization

It was observed that the rate of coating depended strongly on the type of carbon fibre. It appears that the degree of graphitization of fibre samples plays an important role in coating. In order to determine the degree of graphitization of the fibres, X-ray diffraction was done on PAN base, pitch base and CVD fibres using the powder diffraction technique. Pure polycrystalline graphite YU60ST from Ultra Carbon Corp. and the three types of fibres were ground to a powder form individually and stacked on sample holders. Ethanol was used to hold the powder together. X-ray diffraction was done on all four samples at the same current and potential settings using a Philips X-ray diffractometer ( $\text{CuK}\alpha$ ,  $0.154178 \text{ nm}$ ) to ensure reproducible peak intensities. The amount of graphite in each powder specimen was analysed by measuring the area under the (002) peak. Coated fibres were inspected with a scanning electron microscope (SEM) to determine the coating thickness and the coating morphology.

## 2.3. Mechanical testing of fibres

Tensile strengths and tensile moduli of PAN base fibres and SiC fibres, before and after coating, were measured by a high-sensitivity load cell connected to an Instron tensile testing machine. The sizing on the fibres was dissolved in acetone and water. A single filament of coated or bare fibre was then glued to a paper holder as shown in Fig. 1 using an epoxy adhesive. The adhesive was allowed to set for 24 h. After loading the fixture, the paper holding the fibre was cut. Care was taken to maintain the stress on the

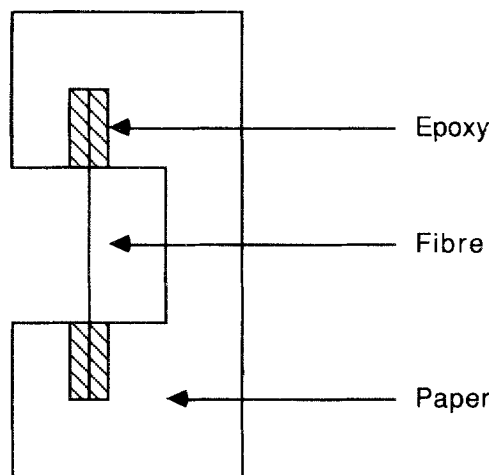

Figure 1 Set-up for testing tensile strength of single-filament fibres.

fibre along the fibre axis direction. The crosshead speed of testing was maintained at  $0.25 \text{ mm min}^{-1}$ .

## 2.4. Composite fabrication

To illustrate the application of coated fibres in composite fabrication, silver-coated fibres (up to 7 vol %) were infiltrated with 6063 Al without the application of external pressures at temperatures around  $1000^\circ\text{C}$ . The procedure adopted is discussed in detail elsewhere [2]. Higher volume fractions (about 25 vol %) of PAN base and SiC fibre-reinforced aluminium-matrix composites were fabricated using a low-pressure technique at temperatures around  $700^\circ\text{C}$ . Details of the low-pressure process will appear separately [11].

## 3. Results and discussion

### 3.1. Growth of the coating and the degree of graphitization

The thickness of silver deposition on CVD, pitch base and PAN base fibres as a function of the coating time is shown in Fig. 2. The average thickness of silver coating after 30 min was  $3 \mu\text{m}$  on CVD fibres,  $0.7 \mu\text{m}$  on pitch base fibres and  $0.3 \mu\text{m}$  on PAN base fibres. The average thickness of copper after 10 min of deposition was about  $0.5 \mu\text{m}$  for CVD fibres, about  $0.2 \mu\text{m}$  for pitch base fibres and about  $0.1 \mu\text{m}$  for PAN base fibres.

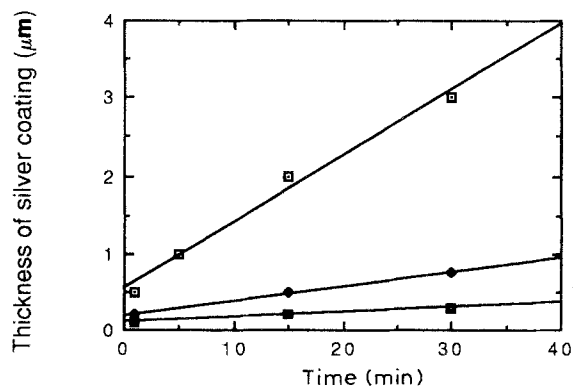

Figure 2 Variation in thickness of silver coating with time for different types of carbon fibres: ( $\square$ ) CVD, ( $\blacklozenge$ ) pitch base, ( $\blacksquare$ ) PAN base.

The morphology of coated CVD graphite fibres is shown in Fig. 3; pitch base graphite fibres in Fig. 4; and PAN base carbon fibres in Fig. 5. All these figures show uniform silver coatings. The thickness of both

copper and silver deposited was found to be the least in PAN base fibres and the largest in the case of CVD fibres, plated under similar conditions.

The thickness of silver coating was observed to be a

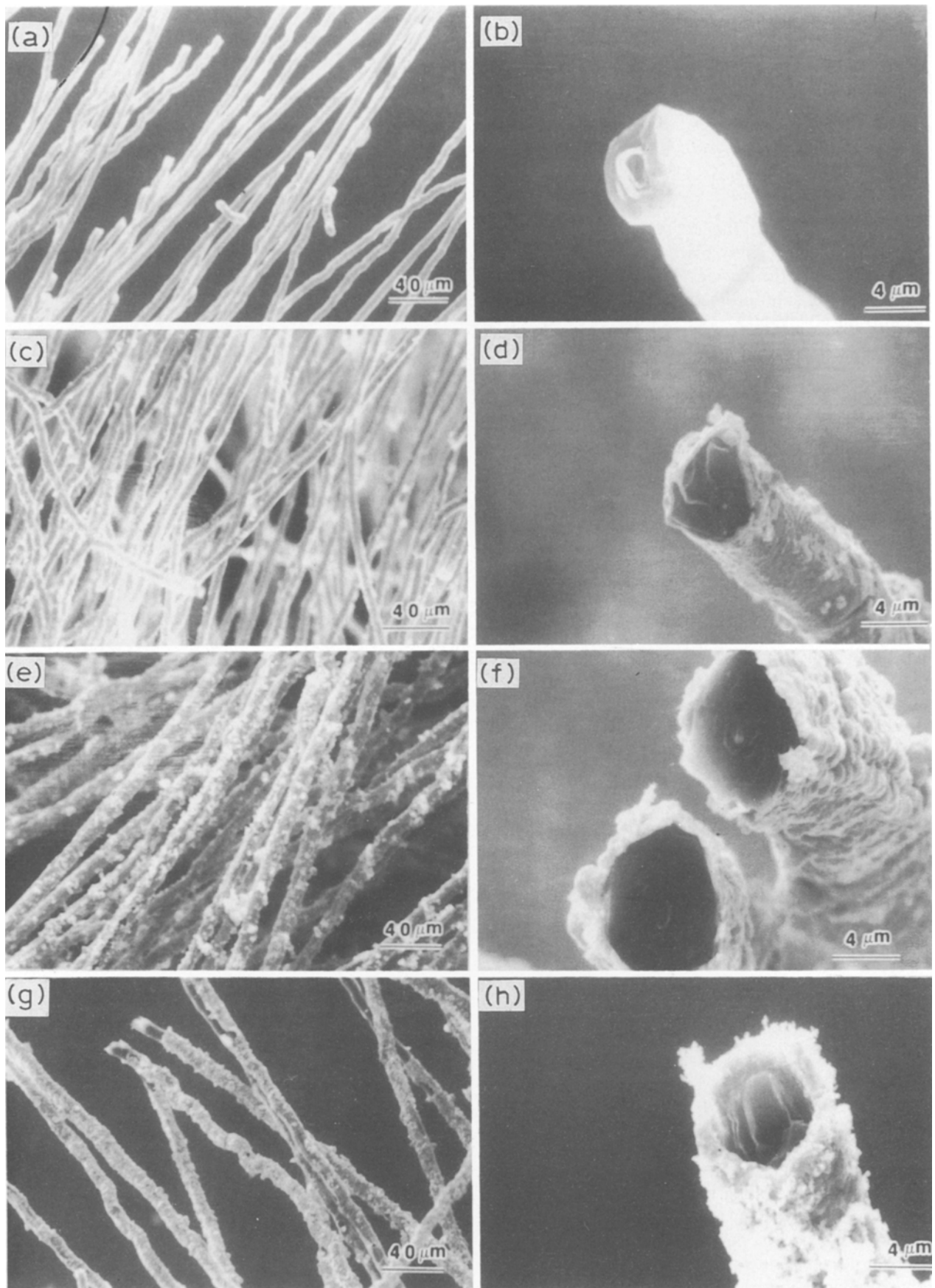

Figure 3 Morphology of CVD fibres: (a, b) as received; (c, d) coated with copper for 10 min; (e, f) coated with silver for 15 min; (g, h) coated with silver for 30 min.

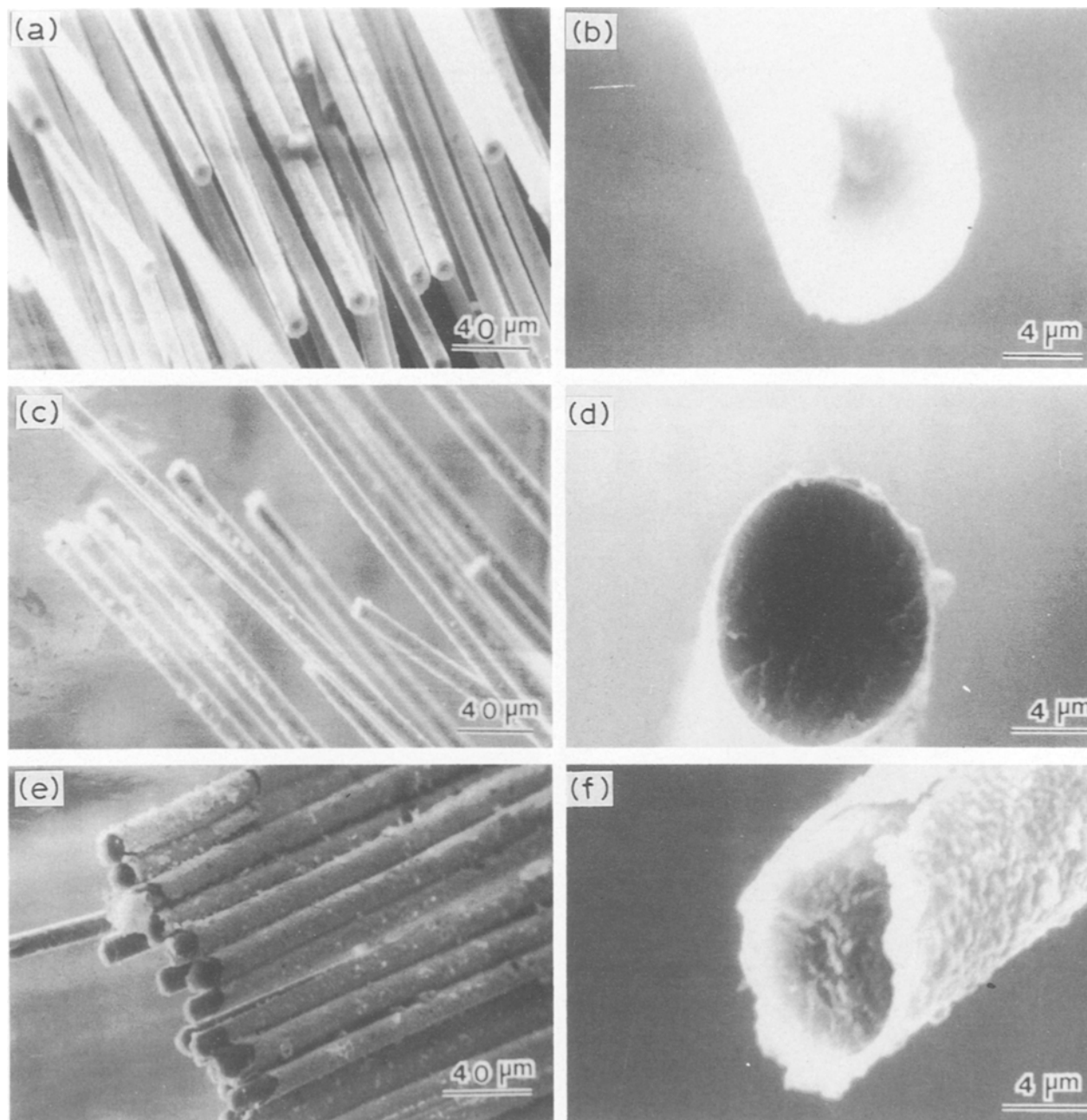

Figure 4 Morphology of pitch base fibres: (a, b) as received; (c, d) coated with copper for 10 min; (e, f) coated with silver for 15 min.

linear function of time in all three fibres. The slope of the line reflects the deposition rate. None of these lines go through the origin. Instead, at time zero, the lines intercept the ordinate at a certain positive thickness. This implies that immediately after the start of the deposition, a finite amount of coating occurred through a process different from the later stage of the coating. It is likely that this initial thickness reflects the extent of the displacement reaction between  $\text{Ag}^+$  and Cu occurring almost instantly at the beginning of deposition. It can be seen that the coating rate for CVD fibres is greater than that of pitch base fibres, which is, in turn, greater than that of PAN base fibres. The intercept values show that the extent of the displacement reaction (or the thickness of copper deposited, assuming that Ag ions replace Cu spontaneously) for CVD fibres is greater than that of pitch

base fibres, which is, in turn, greater than that of PAN base fibres.

To understand this behaviour, X-ray diffraction pattern of the three types of fibres were compared with that of pure graphite (Figs 6 to 9). X-ray analysis gave an amorphous scatter for PAN base fibres (Fig. 6) and three distinct peaks for both pitch base (Fig. 7) and CVD fibres (Fig. 8). In order to do the quantitative analysis of the integrated intensity of the most prominent peak, the diffraction analysis were performed at a reduced speed of  $0.25^\circ \text{min}^{-1}$  from  $24$  to  $28^\circ$  ( $2\theta$ ) values. This was done to enhance the diffraction pattern and increase the measurement accuracy. Pure polycrystalline graphite (99.5%) was also tested in a similar way (Fig. 9). The area under the curve was calculated by multiplying the full width at half intensity with the maximum intensity of the peak. The

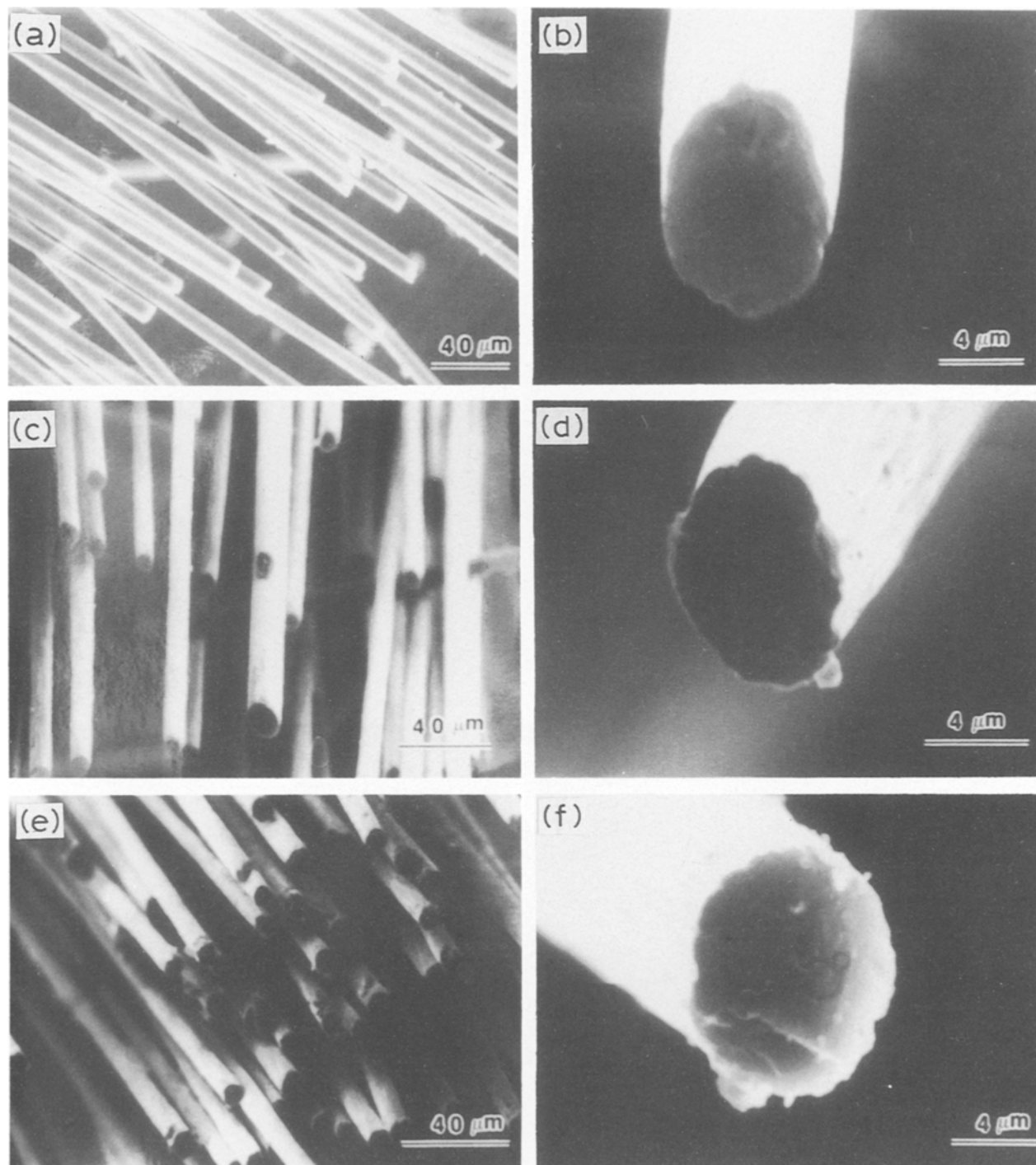

Figure 5 Morphology of PAN base fibres: (a, b) as received; (c, d) coated with copper for 10 min; (e, f) coated with silver for 15 min.

results indicate that the degree of graphitization was about 96% in the case of CVD fibres and about 66% in the case of pitch base fibres, on a comparative scale (Table I). Pan base fibres, which lack long-range periodicity and are likely to possess a microcrystalline structure, are considered to have zero degree of graphitization.

A plot of the rate of silver deposition obtained from the slope in Fig. 1 versus the degree of graphitization (Fig. 10) and that of the thickness of copper deposited versus the degree of graphitization (Fig. 11) show that the coating thickness of copper and silver increases with the degree of graphitization. The reason for this

behaviour could be due to the preferred high-energy sites associated with the crystallinity of graphite.

### 3.2. Structure of graphite and growth of the coating

In a graphite fibre, the stacking arrangements of carbon atoms are slightly displaced from their regular positions in a perfect graphite crystal [12]. During graphitization, carbon atoms orient themselves in a preferred manner with the basal planes parallel to the fibre axis. Since the basal planes are relatively inert as compared to the high-energy basal plane edges [13],

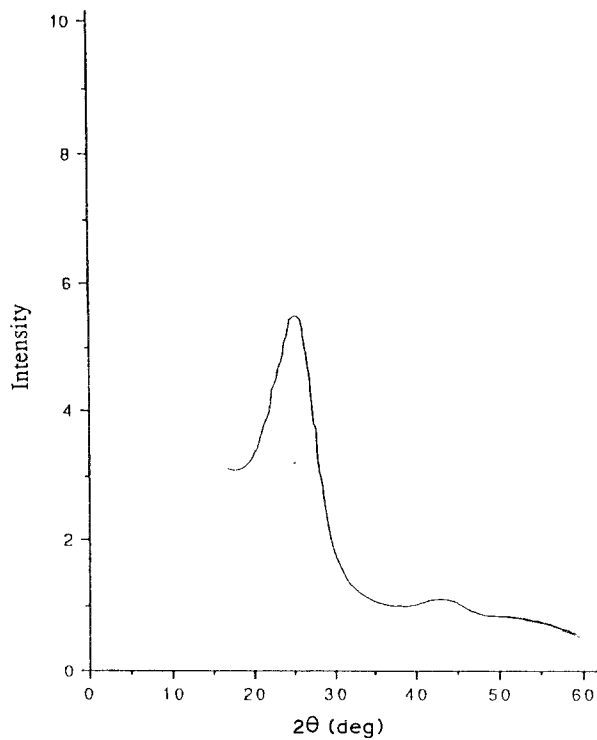

Figure 6 X-ray diffractogram of PAN base fibres: range =  $3 \times 10^3$ , time constant = 0.3.

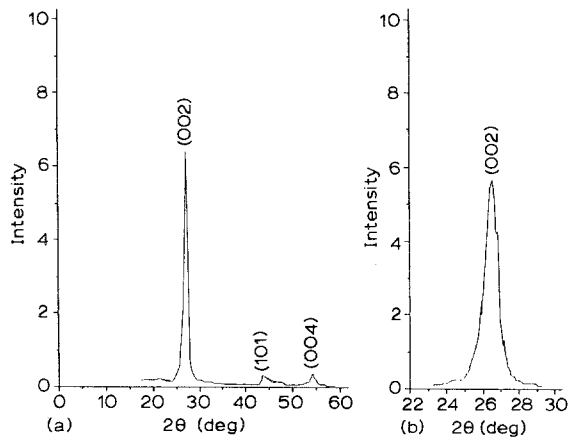

Figure 7 (a, b) X-ray diffractograms of pitch base fibres: range =  $3 \times 10^3$ , time constant = 0.3.

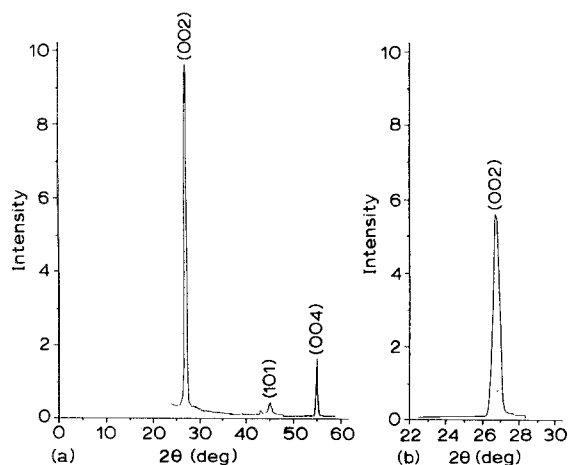

Figure 8 X-ray diffractograms of CVD fibres: (a) range =  $3 \times 10^3$ , time constant = 0.3, (b) range =  $10^4$ , time constant = 0.1.

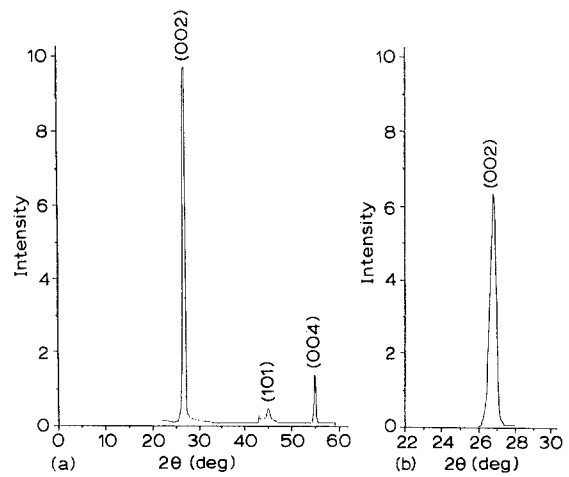

Figure 9 X-ray diffractogram of pure graphite: (a) range =  $3 \times 10^3$ , time constant = 0.3, (b) range =  $10^4$ , time constant = 0.1.

TABLE I Degree of graphitization in graphite fibres

Type of material	Integrated intensity from (002) peak (counts)	Degree of graphitization (%)
Pure graphite	428 625	99.5
CVD fibre	413 100	95.9
Pitch base fibre	283 500	65.8
PAN base fibre	—	—

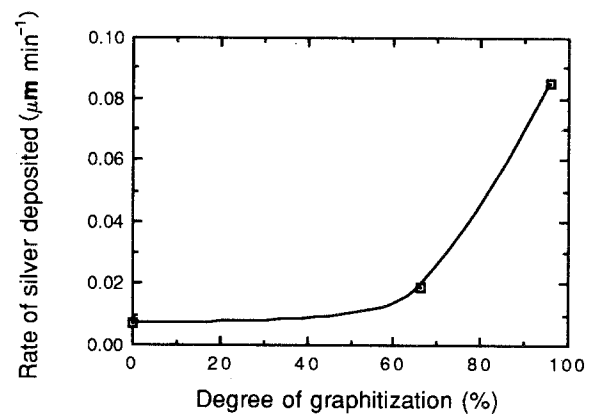

Figure 10 Variation in the rate of silver deposited with the degree of graphitization.

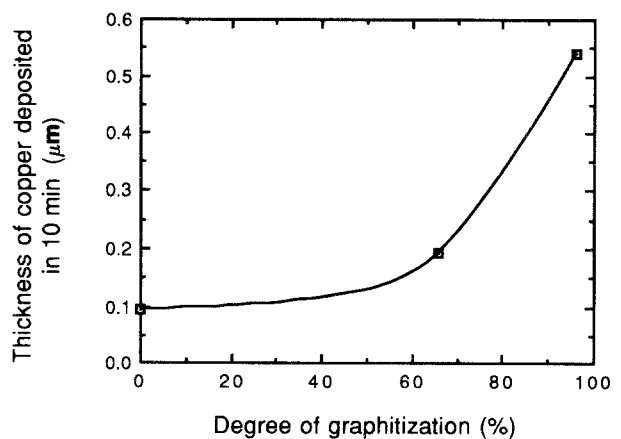

Figure 11 Variation in the rate of copper deposited with the degree of graphitization.

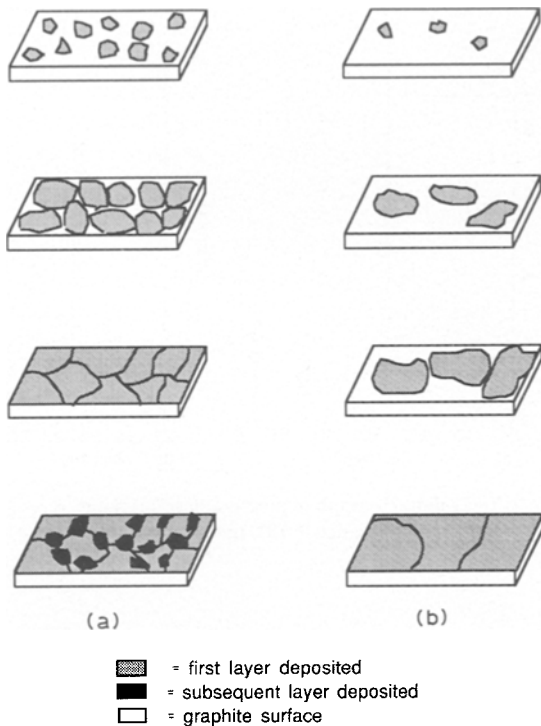

Figure 12 Comparison of the way deposition might proceed after identical times on fibres with (a) high and (b) low degree of graphitization.

during the sensitization and catalysis treatments it can be expected that these edges would get activated to a greater extent than the basal planes. In a perfect graphite fibre, with all the basal planes oriented parallel to the fibre axis theoretically, the first layer of the atoms should be deposited at the same time in a very uniform manner. However, commercially available graphite fibres do not have perfect graphitization and are not free of defects.

In the fibres used in this study, the degree of graphitization varied from 0 to 96% on a comparative scale. Since these fibres were not fully graphitized, and also since defects are always present, deposition would not have occurred uniformly at the atomic level. Sites which possess high energies would have been occupied first. Subsequent growth of the coating is more than likely to have occurred in a direction parallel to the fibre axis until various nuclei (domains) impinge upon each other and stop lateral growth. Further deposition on top of the first layer would have started again in high-energy areas, such as the grain boundaries in the first layer.

As the degree of graphitization decreases, the gap between the nuclei formed initially would increase. This would cause larger grains to be formed. The smaller amount of grain boundaries would keep the growth rate of the coating low. A comparison of the way deposition would proceed on fibres with a variation in the degree of graphitization is schematically shown in Fig. 12.

### 3.3. Tensile properties of coated fibres

Tensile properties of coated and uncoated fibres are shown in Table II. Rows 2 and 4 show the strengths

TABLE II Tensile properties of coated and uncoated PAN and SiC fibres<sup>a</sup>

Fibre/coating	Tensile strength (GPa)	Tensile modulus (GPa)
SiC/-	2.2	146
SiC/Ag	2.5	145
PAN/-	2.4	197
PAN/Ag	2.4	193

<sup>a</sup> The strength and modulus of SiC fibres are 2.7 and 200 GPa, respectively, from Ishikawa *et al.* [14]; The strength and modulus of PAN fibres are 2.8 and 221 GPa, respectively, from Schoutens *et al.* [15]; The average diameter of SiC fibres was 19.2  $\mu\text{m}$  and that of PAN fibres was 8.4  $\mu\text{m}$ .

and moduli of SiC and PAN base fibres, respectively, after coating, in which the diameter of the fibres is taken as that of the uncoated fibres because the contribution from the silver layer in carrying the load is very small compared to that of the fibre. The contribution to load-sharing from silver is only about 1% in the case of SiC fibres and about 1.7% in the case of PAN base fibre (considering the tensile strength and modulus of silver to be 0.130 and 71 GPa, respectively [16]). Results from Table II indicate a slight increase in the tensile strength of SiC fibres after coating with silver. There appears to be an insignificant change in the strength values of PAN base fibres after coating. The modulus of the coated fibres in the case of both PAN base fibres and SiC fibres is quite similar to that of the untreated fibres.

The lower value of strength in uncoated SiC fibres as compared to data reported in the literature could be due to the presence of surface defects. A nominal increase in the strength of SiC fibres after coating could be expected, because the silver on the fibre surface would have covered the defect sites and thus could have reduced the effect of surface defects on stress concentration in the fracture of the fibre. This variation was not observed in PAN base fibres. The reason could be that the surface defects in PAN base fibres are less pronounced than those of SiC fibres and therefore, the strength-enhancing ability of the coating might not be as noticeable.

The rule-of-mixture calculations as seen in Table III show that the theoretical value of the tensile strength and modulus of silver-coated fibres is almost equal to that obtained from the experiment. The strength and modulus of SiC fibres after coating, considering the total diameter of the coated fibre, are about 100 and 91% of the rule-of-mixture values and those of PAN base fibres are 100 and 90%, respectively.

TABLE III Tensile values of silver-coated PAN and SiC fibres

Fibre coating	Volume fraction of fibre	Rule of mixtures		Experimental	
		strength (GPa)	modulus (GPa)	strength (GPa)	modulus (GPa)
SiC/Ag	79	2.0	129.4	2.0	117.6
PAN/Ag	71	1.8	158.4	1.8	142.2

### 3.4. Interfaces in Al-C and Al-SiC composites

To verify the effect of silver coating on the interfacial reaction between carbon fibres and aluminium, composites were made with both coated and uncoated fibres. As observed in Fig. 13, the metal-fibre interfaces of composites with uncoated fibres (CVD and pitch base) show a greater extent of reaction than those with coated fibres. In the case of PAN base fibres, silver was found to have significantly improved the wetting characteristics of the fibre, enabling infiltration by molten aluminium. A detailed explanation is supplied elsewhere [2].

Al-SiC composites were also made to study the

effect of silver coating on the processing of the composites. SiC fibres were coated with silver using the same technique. Cross-sections of silver-coated SiC fibres are shown in Fig. 14. It was observed that the silver coating significantly improved the wetting characteristics of the fibre. Fig. 15 shows composites made with and without the coating. We observed that if the fibres were not coated with silver, then they would be rejected by the solidifying melt because of their non-wetting characteristics, thus causing voids in the composite, but coated fibres helped wetting and acceptance of the fibres in molten aluminium. The details of this aspect will appear separately [11].

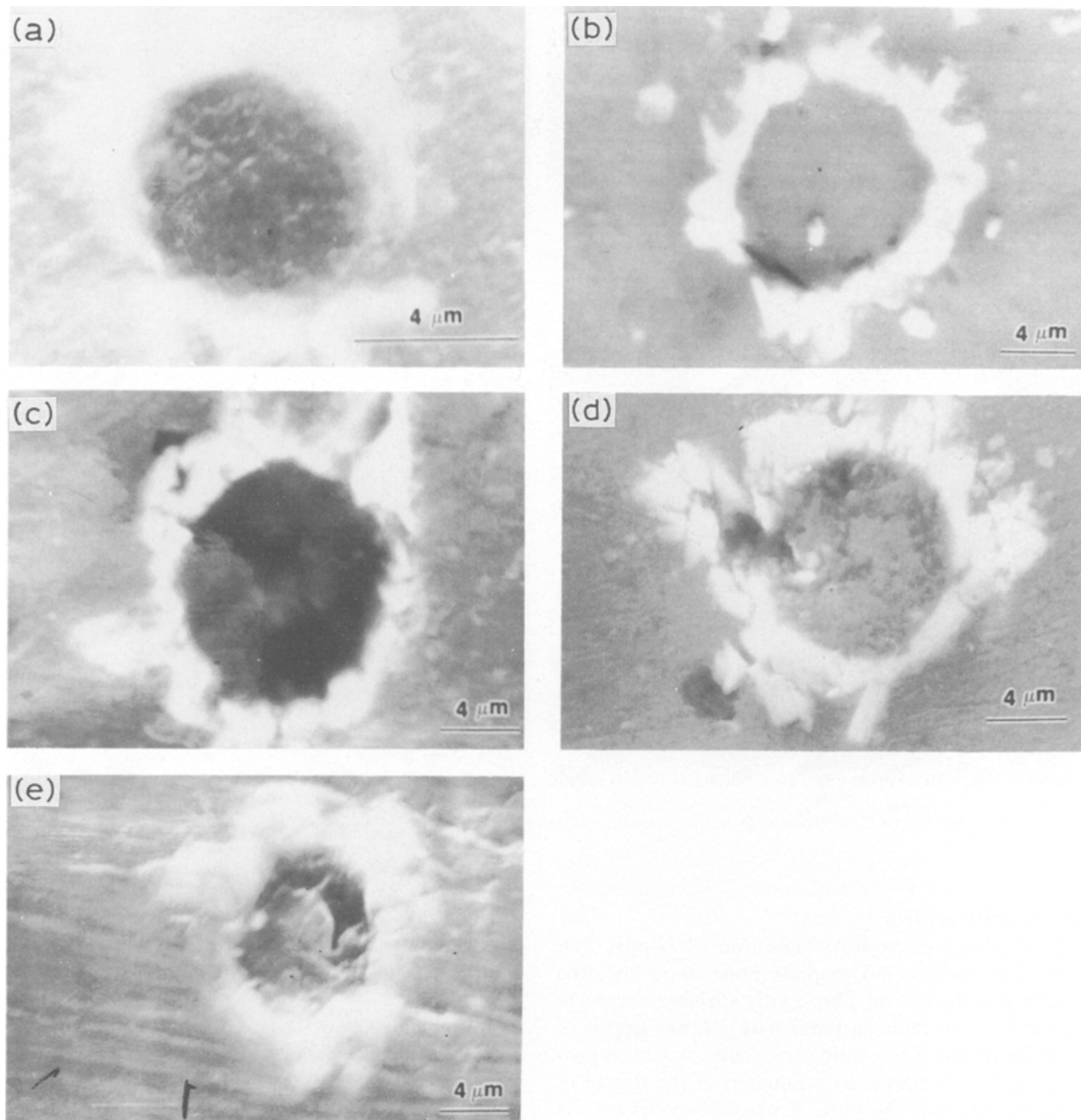

Figure 13 Interfaces in Al-C composites fabricated at 1000 °C for 120 min: CVD fibre (a) with and (b) without silver coating; pitch base fibres (c) with and (d) without silver coating; (e) PAN base fibre with silver coating.



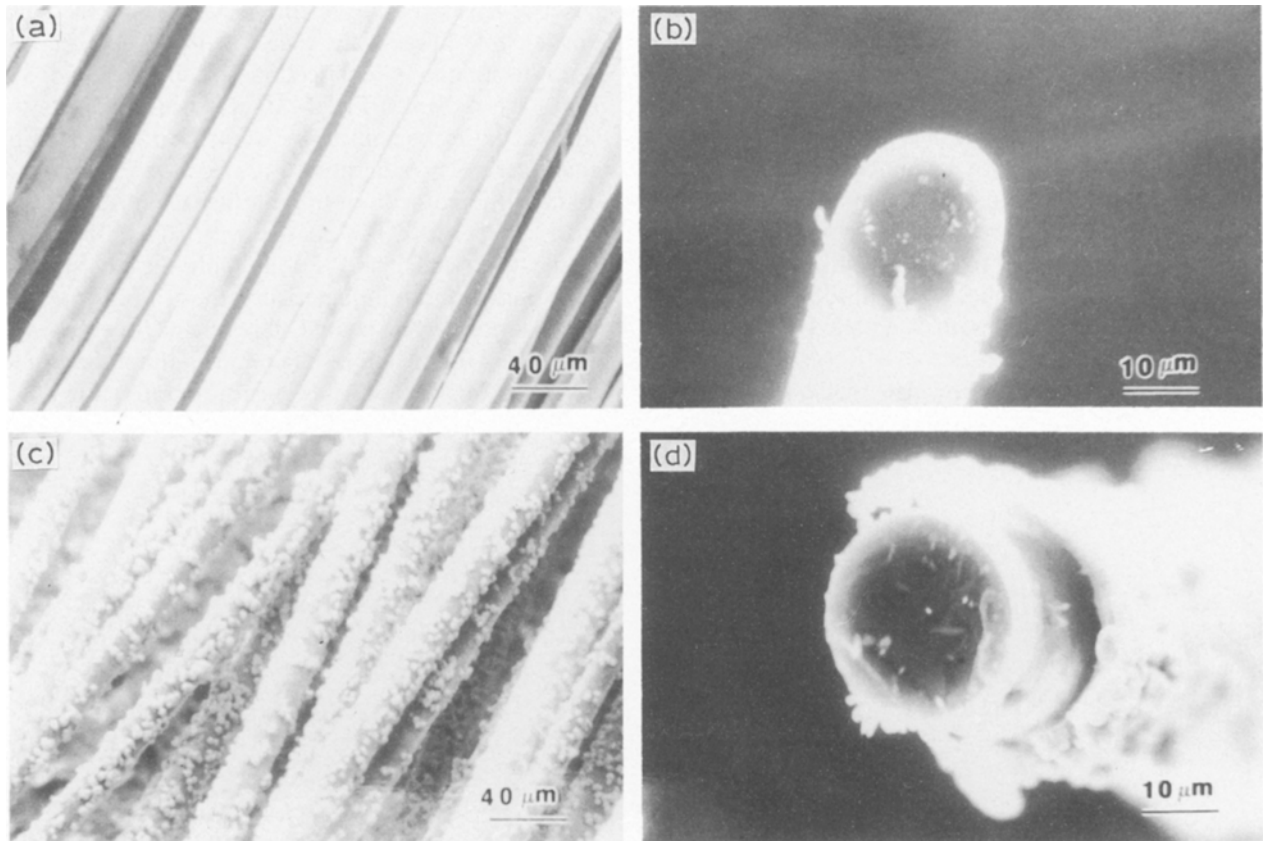

Figure 14 Morphology of SiC fibres: (a, b) as received; (c, d) coated with silver for 15 min.

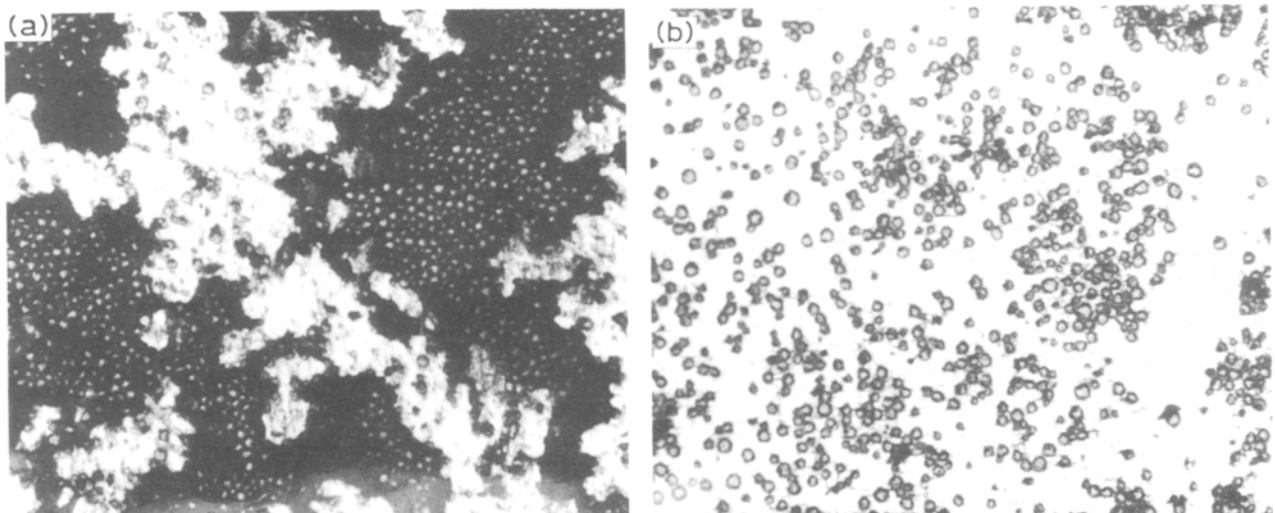

Figure 15 Al-SiC (25 vol %) composites (a) without and (b) with silver coating.

#### 4. Conclusions

Results from electroless deposition of copper and silver on carbon and graphite fibres show that the coating is thicker on fibres with a higher degree of graphitization than on fibres with a lower degree of graphitization. The coating thickness, in a fixed processing time, behaves as a function of the degree of graphitization of the fibre. A physical model for the nucleation and growth of the coating has been proposed. By this mechanism, the coating nucleated on high-energy basal plane edges. Subsequent growth of

the coating occurred by lateral growth. This model suggests that after a layer is formed, further deposition would start at the grain boundaries of the previous layer.

A slight increase in the tensile strength of coated SiC fibres was observed as compared to uncoated fibres. This was thought to be due to strengthening of the fibre from the reduction of surface defects after coating. The strength of PAN base fibres and the modulus of both the fibres were almost unchanged after the treatment. The strengths and moduli of the single-

filament composites were about 100 and 90% of the rule-of-mixtures values.

Silver played a significant role in the fabrication of the composites. On top of helping initial wetting of the fibres, silver coating helped in keeping the fibre surface clean during processing. Coated CVD and pitch base graphite fibres showed a smaller reaction zone than uncoated fibres when infiltrated with liquid aluminium. Silver was found to help wetting, especially in PAN base carbon fibres at high processing temperatures with a pressureless infiltration technique. Silver coating on SiC fibres and PAN base fibres helped wetting at lower processing temperatures with a low pressure infiltration technique.

### Acknowledgements

The authors wish to acknowledge support from the Ohio Edison Program and Applied Sciences Incorporated. The authors also wish to acknowledge help from John Whitaker in setting up the tensile facility.

### References

1. N. EUSTATHOPOULOS, J. C. JOUD, P. DESRE and J. M. HICTER, *J. Mater. Sci.* **9** (1974) 1233.
2. S. G. WARRIER, C. A. BLUE and R. Y. LIN, *ibid.* **28** (1993) 760.
3. M. F. AMATEAU, *J. Compos. Mater.* **10** (1976) 279.
4. I. H. KHAN, *Metall. Trans.* **7A** (1976) 1281.

5. R. V. SARA, "Integrated Research on Carbon Composite Materials", AFML-TR-66-310 (Wright Patterson AFB, Dayton, Ohio, 1966) p. 193.
6. H. M. CHENG, B. L. ZHOU, Z. G. ZHENG, Z. M. WANG and C. X. SHI, *Plating Surf. Finishing* **77**(5) (1990) 130.
7. A. A. BAKER, C. SHIPMAN and P. W. JACKSON, *Fiber Sci. Technol.* **5** (1972) 213.
8. E. De LAMOTTE, K. PHILIPS, A. J. PERRY and H. R. KILLIAS, *J. Mater. Sci.* **7** (1972) 346.
9. E. IGNATOWITZ, *Aluminum* **50** (1974) 334.
10. B. K. CHEN, T. MA and Y. S. WU, in Proceedings of ICCM V, San Diego, 1985, edited by W. C. Harrigan, J. Strife and A. K. Dhingra. Metallurgical Society, Warrendale Pennsylvania, 1985) p. 709.
11. S. G. WARRIER and R. Y. LIN, to be published.
12. D. M. RIGGS, R. J. SHUFORD and R. W. LEWIS, in "Handbook of Composites", edited by G. Lubin (Van Nostrand Reinhold, 1982) p. 196.
13. D. FINELLO, PhD thesis 1982. 22, University of Texas at Austin (1982).
14. T. ISHIKAWA, H. ICHIKAWA and H. TERANISHI, Presented at International Electrochemical Society Meeting, Honolulu, Hawaii, October 1987. Proceedings of the Electrochemical Society (Princeton, NJ, 1988) pp. 88-95.
15. J. E. SCHOUTENS and K. TEMPO, "Introduction to Metal Matrix Composite Materials", MMCIAC Tutorial Series No. 272 (DOD MMCIAC, Santa Barbara, CA, 1982) p. 2-38.
16. A. A. JOHNSON and J. A. VON FRAUNHOFER, "Metals Handbook", Desk Edn, edited by H. E. Boyer and T. L. Gall (ASM, Metals Park, Ohio, 1985) p. 13.1.

*Received 15 November 1992*

*and accepted 24 February 1993*